



Wood chips for pulp production

Thickness and thickness distribution

1 Scope

This SCAN-test Method describes the procedure and the apparatus for determining the mean thickness and thickness distribution of wood chips intended for the production of chemical or mechanical pulps.

The Method is applicable to the determination of the quality of wood chips. The thickness is an important property of wood chips, since the thickness influences the ease of impregnation with water and chemicals.

2 References

- SCAN-CM 39 Wood chips for pulp production – Dry matter content
- SCAN-CM 40 Wood chips for pulp production – Size distribution
- SCAN-CM 41 Wood chips for pulp production – Sampling

3 Definitions

For the purpose of this Method, the following definitions apply:

3.1 *Thickness classification* – A procedure for separating, by means of a series of screens, a sample of wood chips into fractions according to thickness.

3.2 *Thickness classifier* – Apparatus for chip classification according to thickness.

4 Principle

A classifier is used to separate the chip sample into different classes according to thickness by screening the chips for a given time through a stack of horizontal screen trays of specified dimensions having slots of different sizes. The six fractions obtained are then weighed separately. This gives the thickness distribution. The mean thickness is achieved by calculation.

5 Apparatus

5.1 *Thickness classifier* having 5 screen trays, *Figure 1*, and a fines pan.

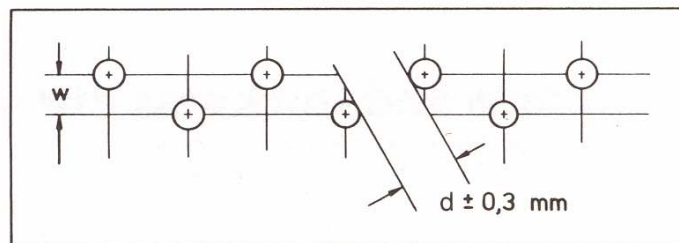
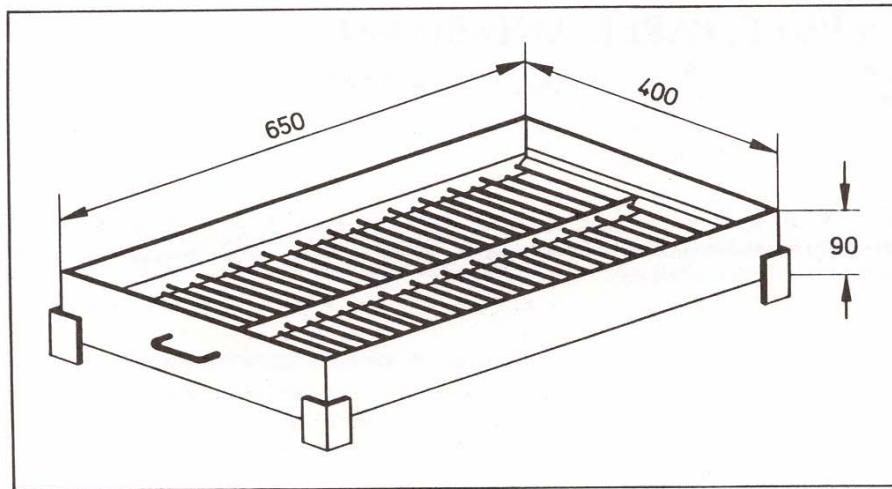

Figure 1. Picture of a screen tray showing the tray dimensions and identifying the arrangements of the rods according to Table 1.

The frame dimensions are 650 mm x 400 mm. The frame rims are 90 mm high. The fines pan has the same dimensions as the screen trays. The five trays shall be mounted on top of the fines pan to form a stack.

Note 1 – In some classifiers, the fines pan is larger than the trays specified here and mounted in a fixed position under the shaking frames. Such a classifier is considered as complying to this Method, provided that measures have been taken to avoid loss of sample by dusting or when emptying the pan before weighing the fines.

The following specifications shall apply to the five screen trays, *Table 1 and Figure 1*.

The bottom of all screen tray shall consist of parallel, cylindrical rods, with a diameter of 5 mm. In all screen trays, each second rod is at a lower level than the others. The free distance between adjacent rods defines the size of the slot and varies therefore between the different screen trays according to *Table 1*. The mean free distance between adjacent rods, *d*, shall be respectively for the five different screen trays: 2,0;

4,0; 6,0; 8,0 and 10,0 mm. The mean allowable discrepancy at any point for a single tray is $\pm 0,1$ mm and the maximum discrepancy is $\pm 0,3$ mm. The vertical distance, *w*, between the two set of rods (centre to centre) is also given in *Table 1*.

*Table 1. The free distance, *d*, between adjacent rods and the vertical distance, *w*, between the two set of rods (centre to centre) in the different screen trays (cf. Figure 1).*

Stack of screen trays	Distance <i>d</i> , mm	Distance <i>w</i> , mm
First tray	10	6,50
Second tray	8	6,25
Third tray	6	5,00
Fourth tray	4	4,50
Fifth tray	2	4,00
Fines pan	-	-



The rods are parallel to the short side of the screen tray and may be supported by a vertical plate, parallel to the longer rims of the screen tray. This plate must not protrude more than 5 mm over the top rods and the maximum thickness of this plate is 4 mm.

The cylindrical rods of the screen trays are made of stainless steel. The other parts of the trays may be made of aluminium, stainless steel or other suitable material.

The stack, with the fines pan, shall be firmly fastened on a frame which is shaken. The frame has a mechanism which gives it a reciprocating motion along a line parallel to the longer side of the tray. The frame must be guided so that it cannot move in the direction parallel to the shorter side of the trays. The motion in the vertical direction must not exceed 5 mm.

The stroke (the movement in the direction parallel to the longer side of the trays) is 120 mm and the frequency 160 ± 10 cycles per minute.

Note 2 – The dimensions of the screens should be checked regularly. Deposits of sticky material (resin etc.) shall be removed with the aid of a suitable solvent, such as acetone or alcohol.

5.2 *Balance*, accurate and readable to 0,1 g.

6 Sampling and preparation of sample

The sampling procedure is not covered by this Method. Make sure that sampling has been carried out in a manner that ensures representative samples. A suitable procedure is described in SCAN-CM 41.

The test portion for each fractionation is 8 to 10 litres. If the sample has to be subdivided to obtain test portions of that size, take precautions to avoid any fractionation of the material.

The dry matter content of the sample should be within the range from 40 to 70 %. If the sample is wet and has a dry matter content of less than 40 %, dry it to a dry matter content within that range in air at room temperature. The method for determination of dry matter content is described in SCAN-CM 39.

7 Procedure

Arrange the trays in the order given in *Table 1* to form a stack. Mount the stack on the shaking frame. Distribute the test portion, 8 to 10 litres of wood chips, on the top tray. Start the shaking mechanism and shake the stack for 10 minutes. Remove the six fractions obtained and weigh them immediately to the nearest 0,1 g.

Note – No determination of the dry matter content is required. However, it is essential for the accuracy of the result that the material does not gain or lose moisture between the classification

and the weighing. Therefore, weigh the fractions as quickly as possible on a balance placed close to classifier.

8 Calculation and report

8.1 Thickness distribution:

Calculate the total mass of all six fractions and then the mass of each fraction as a percentage, with one decimal, of the whole. Name the fractions in the trays as follows:

- First tray: Chips thickness fraction > 10 mm
- Second tray: Chips thickness fraction 8–10 mm
- Third tray: Chips thickness fraction 6–8 mm
- Fourth tray: Chips thickness fraction 4–6 mm
- Fifth tray: Chips thickness fraction 2–4 mm
- Fines pan: Chips thickness fraction < 2 mm

8.2 Mean thickness:

The mean chip thickness is calculated from the expression:

$$X = \frac{\Sigma(11a_1 + 9a_2 + 7a_3 + 5a_4 + 3a_5 + a_6)}{100} \quad [1]$$

where

- X is the mean chip thickness in millimetres;
- a_n is the percentage share of the whole chip sample in the *n*th thickness fraction.

Note 1 – Each thickness class has an upper and a lower thickness limit. The mean thickness in each class is the average of these limits. For the >10 mm class this average is assumed to be 11 mm and for the < 2 mm fraction it is assumed to be 1 mm.

Note 2 – Actually this mean thickness value gives the width of the slot that will split the chip sample into two parts of the same size by mass (weight).

Report the result with one decimal.

The test report shall include reference to this SCAN-test Method and the following particulars:

- (a) date and place of testing;
- (b) identification mark of the sample tested;
- (c) the results;
- (d) the coefficient of variation;
- (e) any departure from the procedure described in this Method and any other circumstances that may have affected the test results.

9 Precision

Three wood chip samples, with different size distribution characteristics, were tested by two laboratories. The mean thickness and the coefficient of variation within and between laboratories are given in *Table 2*.

Table 2. Mean thickness and the coefficient of variation within a laboratory and between laboratories.

Chip sample	Results within lab		Results between labs	
	Mean thickness mm	CV* %	Mean thickness mm	CV* %
A	6,8	1,2	6,5	3,1
B	5,6	0,9	5,3	3,7
C	6,0	0,6	5,8	1,6

* CV is the coefficient of variation for the thickness distribution

**SCAN-test Methods are issued and recommended by KCL, PFI and STFI-Packforsk for the pulp, paper and board industries in Finland, Norway and Sweden.
Distribution: Secretariat, Scandinavian Pulp, Paper and Board Testing Committee, Box 5604,
SE-114 86 Stockholm, Sweden.**